

UNIVERSITY OF GREATER MANCHESTER
SCHOOL OF ENGINEERING AND BUILT ENVIRONMENT
BSC (HONS) MECHATRONICS
SEMESTER ONE EXAMINATION 2025/2026
ELECTRONIC ENGINEERING FOR MECHATRONICS
MODULE NO: MEC6005

Date: Wednesday 14th January 2026

Time: 2pm – 4pm

INSTRUCTIONS TO CANDIDATES:

There are 6 questions.

Answer any 4 questions.

All questions carry equal marks.

Marks for parts of questions are shown in brackets.

This examination paper carries a total of 100 marks.

Formulae sheet is attached at the end of the paper.

All working must be shown. A numerical solution to a question obtained by programming an electronic calculator will not be accepted.

Question 1

a) Define the following terms (**1.5 marks for each definition**):

- i. Current
- ii. Resistance
- iii. Phase angle
- iv. Internal resistance

[6 marks]

b) You did a measurement between two points in your circuit, and the measured waveform shown on the oscilloscope is presented in the Figure 1.b. Based on the diagram, work out the following: (**2 marks for each**)

- i. Frequency
- ii. Period
- iii. Peak to Peak value
- iv. RMS Value
- v. The equation of this voltage signal

[10 marks]

Figure 1.b, Diagram of the measured voltage signal

c) An AC ammeter reads 11A rms current through a resistive load, and a voltmeter reads 350V rms drop across the load.

- i. What are the peak values and the average values of the alternating current and voltage? **[6 marks]**
- ii. Calculate the load resistance. **[3 marks]**

Total 25 marks**PLEASE TURN THE PAGE**

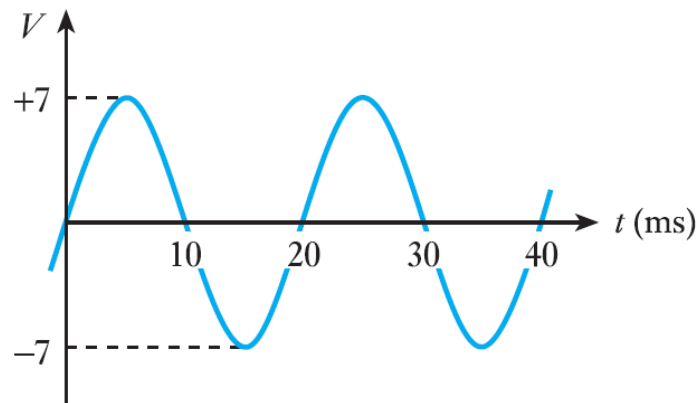
Question 2

- a) For the circuit shown below (Figure 2.a), considering the R_{Load} as the load resistance.

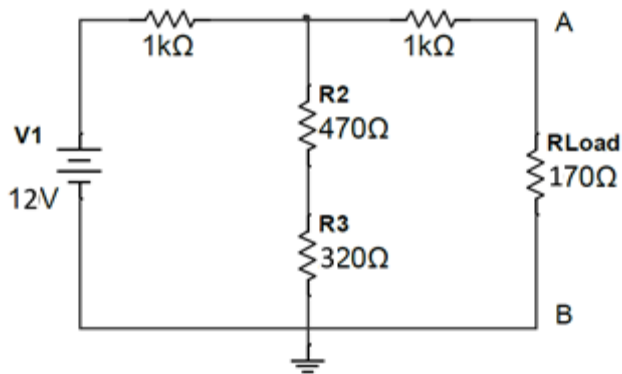

Figure 2.a

- i. Derive the equivalent Thevenin circuit between points "A" and "B". **[10 marks]**
- ii. Derive the equivalent Norton circuit between points "A" and "B". **[5 marks]**
- b) For the following circuit (Figure 2.b), using superposition theorem or otherwise, find out the current flowing through the $10\ \Omega$ resistor.

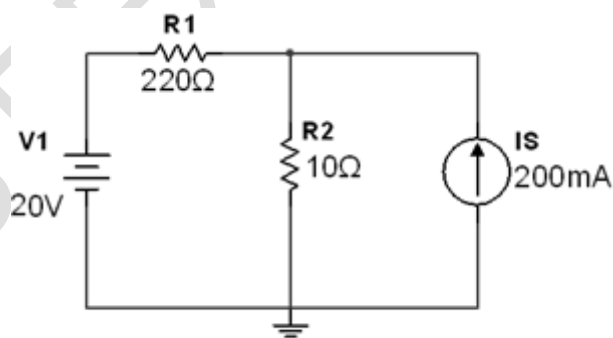

Figure 2.b

[10 marks]**Total 25 marks****PLEASE TURN THE PAGE**

Question 3

- a) Draw a diagram of a parallel plate capacitor showing the charge on the plates and the \mathbf{E} field in the region between the plates. **[4 marks]**
- b) Explain what is meant by the dielectric strength \mathbf{E}_m of an insulator? **[5 marks]**
- c) A $15 \mu\text{F}$ capacitor has 12 V across it. What quantity of charge is stored in it? **[5 marks]**
- d) For the capacitor **charging** circuit shown in Figure 3.d below, where the capacitor is initially discharged, sketch two separate graphs for the current I versus time and the capacitor voltage V_c versus time. **[6 marks]**

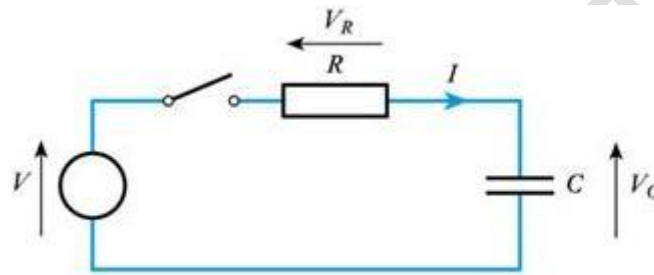

Figure 3.d An initially uncharged capacitor being charged through a resistor.

- e) Explain with the assistance of a diagram what happens to the structure of the curves for I versus time and V_c versus time if the time constant $\tau = RC$ for the circuit increases? **[5 marks]**

[5 marks]

Total 25 marks

PLEASE TURN THE PAGE

Question 4

- a) For the combinational digital circuit shown below in Figure 4.a:

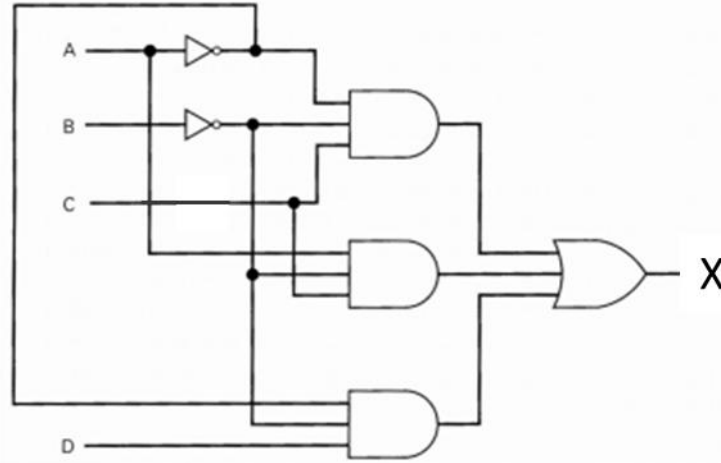

Figure 4.a Digital Circuit diagram

- i) Find out the Boolean expressions at output Q. [5 marks]
 ii) Complete the truth table for this digital circuit. [9 marks]

- b) Fill in the blanks by converting the following numbers into their respective missing decimal and binary equivalents:

- i) $11000_2 = \underline{\hspace{2cm}}_{10}$
 ii) $A_{16} = \underline{\hspace{2cm}}_{10}$
 iii) $\underline{\hspace{2cm}}_{16} = 1306_{10}$
 iv) $1101_2 + 101_2 = \underline{\hspace{2cm}}_2 = \underline{\hspace{2cm}}_{10}$

[5 marks]

- c) Explain what Kirchoff's voltage and current laws are and identify at least two differences between them.

[6 marks]

Total 25 marks

PLEASE TURN THE PAGE

Question 5

For the circuit shown in figure 5, calculate:

- | | |
|---|------------------|
| a) Currents I_1 , I_2 , and I_3 | [9 marks] |
| b) Voltages across R_1 , R_2 , and R_3 | [6 marks] |
| c) Powers P_1 , P_2 , and P_3 | [3 marks] |
| d) Draw the complete voltages and currents phasor diagram | [3 marks] |
| e) The peak I_3 current at resonance frequency | [4 marks] |

Where $v = 17\cos 314t$, $R_1 = R_2 = 2\Omega$, $R_3 = 4\Omega$, $X_{L2} = j2\Omega$, $X_{L3} = j6\Omega$, $X_C = -j4\Omega$

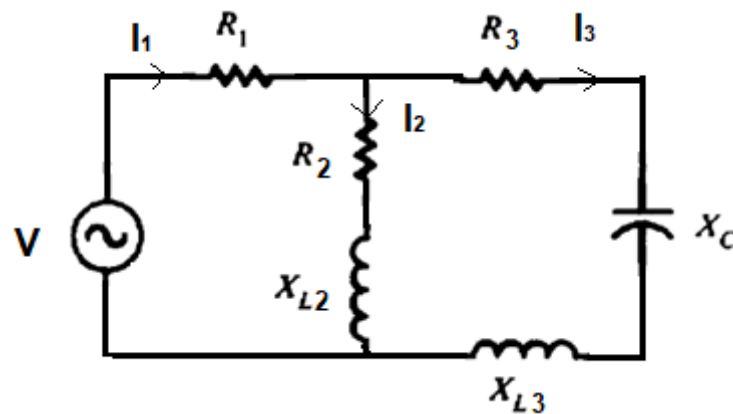

Figure 5

Total 25 marks

PLEASE TURN THE PAGE

Question 6

- a) A Wheatstone bridge arrangement, as shown in figure 6.a, uses strain gauges and resistances of nominal value $R_2 = R_3 = R_4 = 150 \text{ ohm}$, and a 12V excitation voltage. R_1 is the active gauge and R_2 is the dummy gauge.

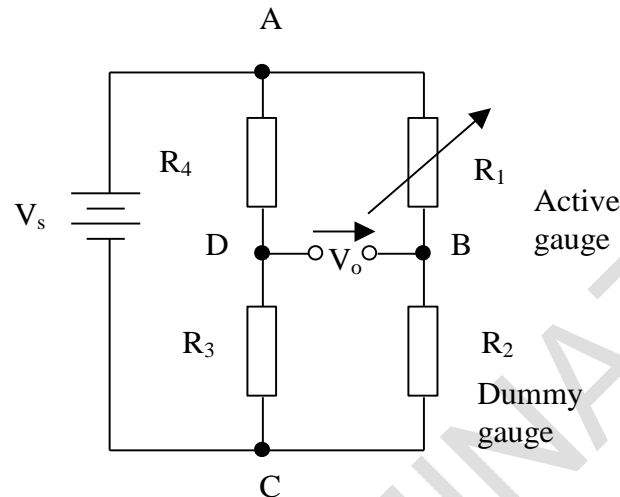

Figure 6.a Wheatstone bridge circuit with strain gauges.

- i) When the bridge is balanced, what value R_1 should be? **[3 marks]**
- ii) An applied loading causes the active strain gauge R_1 to have a resistance increase of $R = 0.0145 \text{ ohm}$. Find the bridge output voltage, V_o , under this condition. **[6 marks]**
- iii) A temperature change causes the two strain gauges to have a resistance change of 8.6 ohm . Find the output voltage in the presence of both stress and temperature resistance changes. **[8 marks]**

Question 6 continued over the page

PLEASE TURN THE PAGE

Question 6 continued

- b) for diagram in Figure 6.b, calculate the equivalent resistance R_E between terminals a and b .

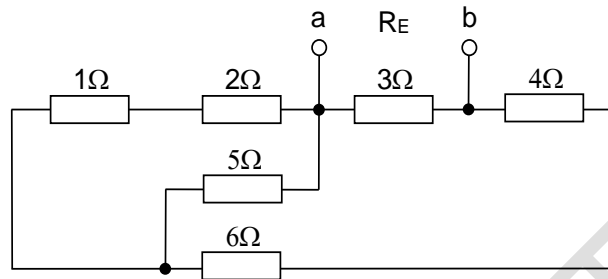

Figure 6.b

[8 marks]**Total 25 marks****END OF QUESTIONS****PLEASE TURN THE PAGE FOR FORMULA SHEET**

School of Engineering and Built Environment
 BSc (Hons) Mechatronics
 Semester One Examination 2025/2026
 Electronic Engineering for Mechatronics
 Module No. MEC6005

APPENDIX: Formula Sheet

The following symbols in the formulae have their standard meaning:

Ohm's law: $V = IR$

Power: $P = IV$

Magnetic flux: $\Phi = BA$

Induced voltage: $V = \Delta\Phi/\Delta t$

Force experienced by charged particle = $qvB\sin\theta$

Motional emf: $E = Blv$

$$f = \frac{pn}{120}$$

Magnitude of the Reactance of Inductor L : $X_L = 2\pi fL$

Magnitude of the Reactance of Capacitor C : $X_C = \frac{1}{2\pi fC}$

Pythagorean theorem: $c^2 = a^2 + b^2$

Tangent function: $\tan A = \text{opposite/adjacent}$

$\mu_0 = 4\pi \times 10^{-7} \text{ H/m}$, $\epsilon_0 = 8.85 \times 10^{-12} \text{ F/m}$

$$H = \frac{NI}{l}, \quad B = \mu H$$

MMF = NI

$$L = \frac{\mu_0 \mu_r AN^2}{l}, \quad E = \frac{1}{2} LI^2$$

$$C = Q/V, \quad C = \frac{\epsilon A}{d}, \quad E = \frac{1}{2} CV^2$$

$$v_L = L \frac{di_L}{dt}$$

$$i_C = C \frac{dv_C}{dt}$$

$$f = \frac{pn}{120}$$

Formula sheet continued over the page
 PLEASE TURN THE PAGE

School of Engineering and Built Environment
 BSc (Hons) Mechatronics
 Semester One Examination 2025/2026
 Electronic Engineering for Mechatronics
 Module No. MEC6005

Formula sheet continued

Transformer voltage ratio: $\frac{V_1}{V_2} = \frac{N_1}{N_2}$, $P=V_1.I_1=V_2.I_2$

Multiply the Value	By	To Get the Value
Peak	2	Peak-to-peak
Peak-to-peak	0.5	Peak
Peak	0.637	Average
Average	1.570	Peak
Peak	0.707	RMS (effective)
RMS (effective)	1.414	Peak
Average	1.110	RMS (effective)
RMS (effective)	0.901	Average

Summary Table for Series and Parallel RL Circuits

X_L and R in Series	X_L and R in Parallel
I the same in X_L and R	V_T the same across X_L and R
$V_T = \sqrt{V_R^2 + V_L^2}$	$I_T = \sqrt{I_R^2 + I_L^2}$
$Z = \sqrt{R^2 + X_L^2} = \frac{V_T}{I}$	$Z_T = \frac{V_T}{I_T}$
V_R lags V_L by 90°	I_L lags I_R by 90°
$\theta = \arctan \frac{X_L}{R}$	$\theta = \arctan \left(-\frac{I_L}{I_R} \right)$

Formula sheet continued over the page
 PLEASE TURN THE PAGE

Formula sheet continued

Summary Table for Series and Parallel RC Circuits

X_C and R in Series	X_C and R in Parallel
<p>I the same in X_C and R</p> <p>$V_T = \sqrt{V_R^2 + V_C^2}$</p> <p>$Z = \sqrt{R^2 + X_C^2} = \frac{V_T}{I}$</p> <p>$V_C$ lags V_R by 90°</p> <p>$\theta = \arctan\left(-\frac{X_C}{R}\right)$</p>	<p>V_T the same across X_C and R</p> <p>$I_T = \sqrt{I_R^2 + I_C^2}$</p> <p>$Z_T = \frac{V_T}{I_T}$</p> <p>$I_C$ leads I_R by 90°</p> <p>$\theta = \arctan \frac{I_C}{I_R}$</p>

Impedance in RLC circuit: $Z = R + j(X_L - X_C)$

Boolean algebra rules

- | | |
|----------------------|-------------------------------|
| 1. $A + 0 = A$ | 7. $A \cdot A = A$ |
| 2. $A + 1 = 1$ | 8. $A \cdot \bar{A} = 0$ |
| 3. $A \cdot 0 = 0$ | 9. $\bar{\bar{A}} = A$ |
| 4. $A \cdot 1 = A$ | 10. $A + AB = A$ |
| 5. $A + A = A$ | 11. $A + \bar{A}B = A + B$ |
| 6. $A + \bar{A} = 1$ | 12. $(A + B)(A + C) = A + BC$ |

END OF PAPER